

WIRELINE TYPE JARS

Lee Oilfield Service Ltd. has been supplying hydraulic jars to the oil and gas industry for over four decades. As a result of a need for a better product Lee Oilfield Service has recently developed and field tested a jar for use in all types of wireline operations.

The Lee Oilfield Service Wireline Jar works by pulling upwards, creating a momentary hydraulic delay in the oil chamber and a sudden release with a free travel which will impact in the Jar giving an upward jarring action. The more upward pull the sooner the Jar will release and impact. You then reset the Jar and do the procedure over again. When jarring lightly you will have to wait longer for the Jar to release.

Lee Oilfield Wireline Jars are designed with the following features:

- (A) Rugged sliding sleeve assembly in the hydraulic chamber, which is very simple and has no intricate parts, which are susceptible to failure.
- (B) Oil chamber is evenly balanced by a moveable double sealed pressure ring.
- (C) The high pressure end of the jar is designed in a way to allow the use of different types of seals at the same time for different operating conditions. This is very important because there is no one seal which meets all well bore conditions.
- (D) Mandrels are coated with tungsten carbide, which resists well bore corrosion much better than previous coatings.
- (E) The top subs are threaded to the mandrels with a tapered thread eliminating the need for pinning.

SERVICING

The Lee Oilfield Wireline Jars are quite simple and can be field serviced. It is desirable to use friction wrenches when breaking the body joints, but if you use pipe wrenches it is important to place wrench on bowl in pressure ring area only. With body joints all broken:

1. Remove bottom sub.
2. Break and unscrew the mandrel, if the mandrel unscrews in the middle, remove the bowl, mandrel B and the pressure ring all together and set aside. Break and unscrew mandrel A. Slide mandrel A out through seal retainer and knocker assembly. Pick up bowl and screw mandrel A onto mandrel B only hand tight and slide the valve, pressure ring and mandrel assembly out through the bottom of the bowl. Separate mandrels again.
3. Unscrew the seal retainer from the knocker and remove fill plug from the knocker.
4. Remove all old seals.
5. Clean and inspect parts for wear and damage.

ASSEMBLY

1. Install new seals.
2. Screw the seal retainer onto the knocker, lightly oil the seals and slide this assembly onto mandrel A and torque mandrel A to specs.
3. Slide the valve onto mandrel B with the smooth face contacting the smooth face of the mandrel and screw mandrel A and B together and torque to specs.
4. Slide the bowl with larger ID first over the mandrel assembly and screw onto the knocker.
5. Screw the fill plug into the knocker but do not tighten at this time. Open tool fully and stand vertically with bottom end of the tool upwards. Fill the jar with the proper oil 3/4" to 1" below bottom of the threads in the bowl. Allow a little time for all of the air to come to the top. Slide the pressure ring onto the mandrel and start it into the bowl until the seals begin to seal. Screw the bottom sub onto the bowl when you get a hydraulic pressure build up, lay the tool at a 30° angle with the fill plug on top at the highest point, loosen the fill plug and finish screwing the bottom sub into the bowl displacing any surplus oil out of the plug hole. Tighten the plug. Tighten body joints to specs.

Note: We recommend that you only use oil that the tool was originally set up with. You can use other types of oil but this will vary the firing time drastically if the viscosity of the oils are not the same.

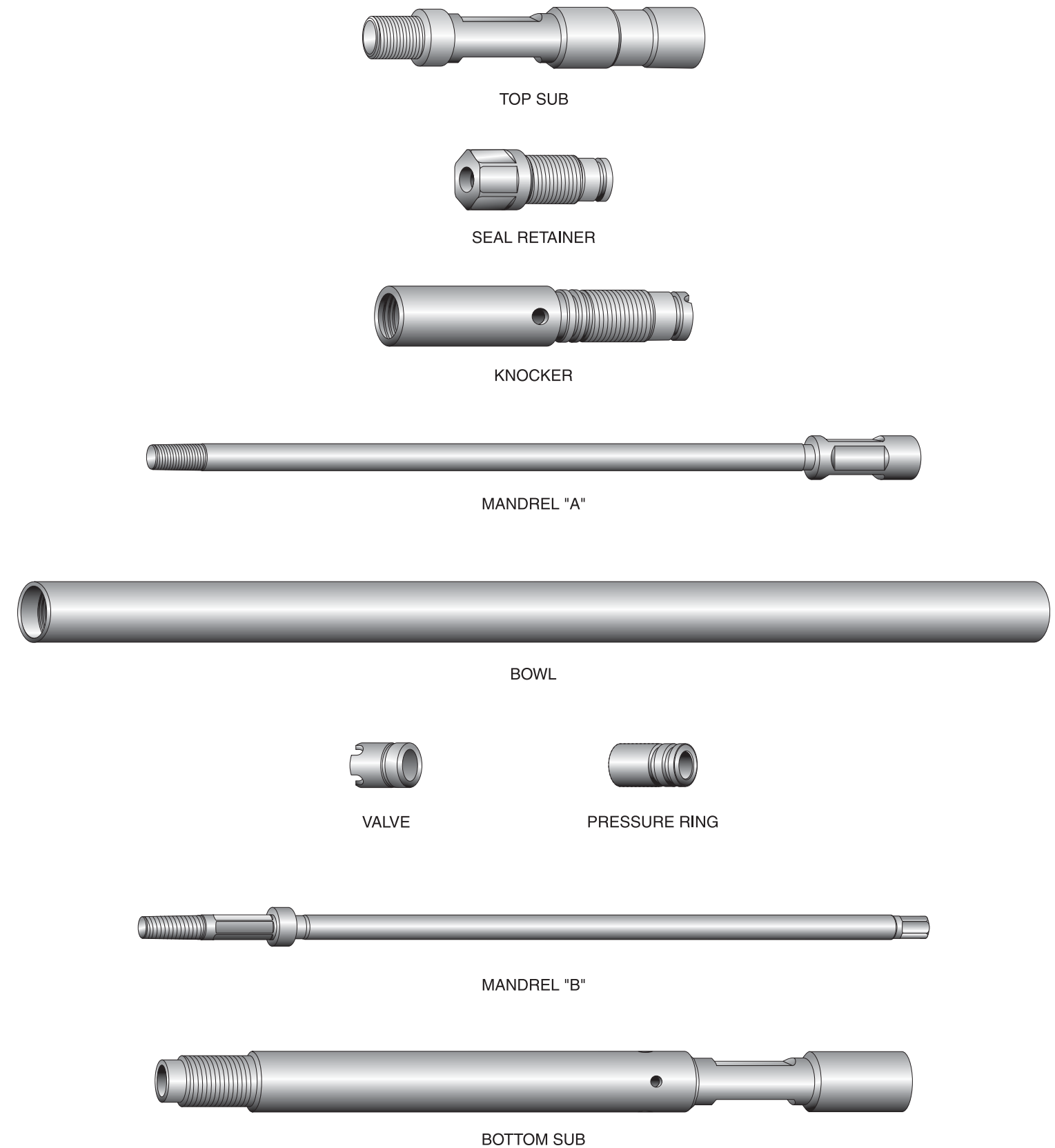

PART	1 1/4" OD 31.8 mm	1 1/2" OD 38.1 mm	1 3/4" OD 44.5 mm	2 1/8" OD 53.9 mm
TOP SUB	WJ-125-01	WJ-150-01	WJ-175-01	WJ-2125-01
SEAL RETAINER	WJ-125-02	WJ-150-02	WJ-175-02	WJ-2125-02
KNOCKER	WJ-125-03	WJ-150-03	WJ-175-03	WJ-2125-03
MANDREL A	WJ-125-04	WJ-150-04	WJ-175-04	WJ-2125-04
MANDREL B	WJ-125-05	WJ-150-05	WJ-175-05	WJ-2125-05
BOWL	WJ-125-06	WJ-150-06	WJ-175-06	WJ-2125-06
VALVE	WJ-125-07	WJ-150-07	WJ-175-07	WJ-2125-07
PRESSURE RING	WJ-125-08	WJ-150-08	WJ-175-08	WJ-2125-08
BOTTOM SUB	WJ-125-09	WJ-150-09	WJ-175-09	WJ-2125-09
SERVICE KIT	WJ-125-10	WJ-150-10	WJ-175-10	WJ-2125-10
COMPLETE UNIT	WJ-125-11	WJ-150-11	WJ-175-11	WJ-2125-11

JAR O.D.	Recommended Jarring Load	Ultimate	Tensile After Jarring	Torque Mandrel A	Torque Mandrel B	Torque Body Joint
1 1/4"	4,000 lbs. 1,750 daN	4,500 lbs. 2,000 daN	18,200 lbs. 8,000 daN	60 ft. lbs.	40 ft. lbs.	70 ft. lbs.
1 1/2"	5,000 lbs. 2,200 daN	6,000 lbs. 2,600 daN	35,000 lbs. 15,500 daN	70 ft. lbs.	50 ft. lbs.	90 ft. lbs.
1 3/4"	6,000 lbs. 2,600 daN	7,100 lbs. 3,100 daN	40,000 lbs. 17,700 daN	90 ft. lbs.	70 ft. lbs.	120 ft. lbs.
2 1/8"	8,000 lbs. 3,500 daN	10,000 lbs. 4,400 daN	70,000 lbs. 31,000 daN	110 ft. lbs.	90 ft. lbs.	150 ft. lbs.

Other sizes available upon request



Manufacturers and Distributors of Hydraulic Jars,
Fishing Bumper Jars and Compounders
Fishing Equipment

**4604 ELENIAC ROAD
EDMONTON, ALBERTA, CANADA T6B 2S1
PHONE (780) 440-6705 • FAX (780) 463-5570**



SERVICE LTD. WL TYPE JARS

